

PROJECT: TYPE:

LOCATION: CAT:



Description
DMX SPI Interface

Features

- SPI signal output for control of RGB/RGBW pixel lights
- DMX512 controllable
- Addressing up to 170 RGB pixels or 128 RGBW pixels individually
- The built-in, back-lit panel allows for easy configuration of most settings
- Four push buttons available for control of the OLED functions
- Supports all Prizm Product varieties
- RGB/RGBW color order configurable
- 512 DMX decoding channels

Mounting

Surface mount

Applications

DMX Pixel Control

Technical Information



Input Voltage Range	12/24V DC
Input Current	max: 0.2A
Input Signal	DMX 512
Output Signal	SPI
DMX Decoding Channel	512 Channels
Driving Pixels	170RGB / 128RGBW
Product Dimension	170x53.4x28mm
Operating Temperature	-20°C (-4°F) ~ 50°C (122°F)
IP Rating	IP20

Order Information

Please allow 12-16 weeks for special order items

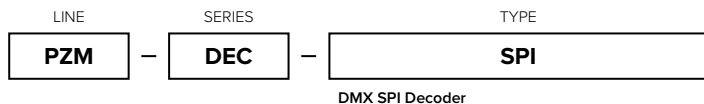

Technical Information

Function Introduction

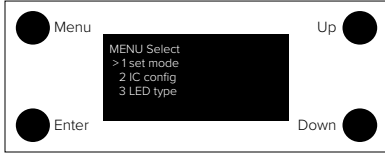

There are four buttons for configuration of setting with the OLED display: “Menu”, “Enter”, “Up” and “Down”, Click “Menu” button to enter the menu selection interface, and keep clicking “Up” and “Down” buttons you will get 5 settings one by one as follows:

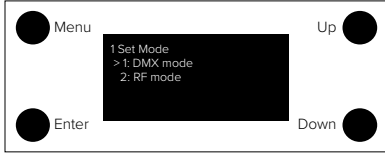

1. Set mode: to select an operation mode, click “Enter” button to enter the configuration interface, then click “Up” and “Down” buttons to choose RF or DMX mode, click “Menu” button to confirm the setting and return to menu selection interface. **RF mode NOT supported in Prizm application.**

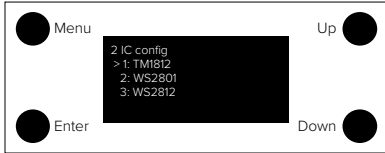

2. IC config: to set driving IC type, click “Enter” button to enter the configuration interface, click “Up” and “Down” buttons to choose an IC type that drives your LED lights, click “Menu” button to confirm and return to menu selection interface. Total 38 kinds of driving IC available. **Only set to “WS2811H” for Prizm Pixel products.**

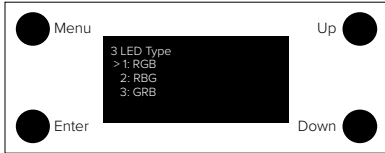

3. LED type: to set RGB/RGBW color order, click “Enter” button to enter the configuration interface, click “Up” and “Down” buttons to choose a color order, click “Menu” button to confirm and return to menu selection interface. Total 7 kinds of color order available. **Set to RGB or RGBW for Prizm Pixel products.**

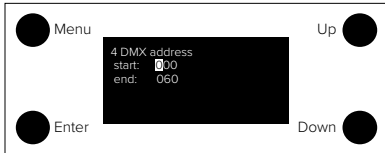

4. DMX address: to set DMX address under DMX mode, click “Enter” button to enter the configuration interface, the cursor will be on the “hundreds” position of the start address, click “Up” and “Down” buttons to change the number, click “Enter” button to confirm and move the cursor to “tens” position and set, and click “Menu” button to confirm the setting and return to menu selection interface. **End number should be greater than total number of Pixel count.**

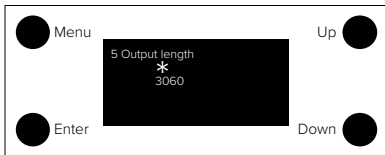

5. Output length: to configure total output channels, click “Enter” button to enter the configuration interface, the asterisk is on the “thousands” position, click “Up” and “Down” buttons to change the number, click “Enter” button to confirm and move the asterisk to “hundreds” position and set, then “tens” position and “units” position, and click “Menu” button to confirm the setting and return to menu selection interface. The SPI controller supports max. 3060 output channels. **Output length must be equal to total number of use DMX address.**

Set mode

The controller has two working modes: RF and DMX. Follow the instructions to choose a mode you would like. Under RF mode, it converts RF signal to SPI signal, and shall be paired to a RF remote. Under DMX mode, it converts standard DMX signal to SPI signal, and can be controlled by universal DMX consoles.

IC config (Setting Pixel Protocol)

This SPI controller works with all common pixel protocols, make sure that the pixel protocol used by your lights is compatible with controller. See the exact 38 protocol types supported as follows:

•WS2801	•LPD1101	•TM1804H	•TM1829L	•UCS1912	•UCS6912	•APA104
•WS2803	•LPD6803	•TM1809L	•TM1829H	•UCS2903	•P9813	•SK6812
• WS2811L*	•LPD8803	•TM1809H	•UCS1903L	•UCS2909L	•D705	
•WS2811H	•LPD8806	•TM1812	•UCS1903H	•UCS2909H	•TLS3001	
•WS2812	•TM1803	•TM1825L	•UCS1909L	•UCS2912	•TLS3002	
•WS2813	•TM1804L	•TM1825H	•UCS1909H	•UCS6909	•APA102	

*NOTE: Do **NOT** use WS2811L

Technical Information

LED type (Setting RGB/RGBW color order)

There are 7 types of RGB/RGBW color order available: RGB, RBG, GRB, GBR, BRG, BGR, RGBW.

DMX address (Setting start and end address)

Under DMX mode, the DMX start address and end address can be set via buttons. The address can be set from 001-512.

For example, when the start address is set as 001, and end address as 003, then the controller will use 3 decoding channels. When the start address is set as 001, and end address as 004, then the controller will use 4 decoding channels. When the start address is set as 001, and end address as 512, then the controller will use 512 decoding channels.

Output length (Setting output channel quantity)

Output length means total output channels or the number of pixels from the start pixel that you would like to address. Each RGB pixel has 3 channels output, and each RGBW pixel has 4 channels output.

For example, when the output length is set as 0003, the controller will be capable of addressing 1 RGB pixel, when the output length is set as 0004, the controller will be capable of addressing 1 RGBW pixel.

Wiring Diagram

1) Connection diagram under DMX system

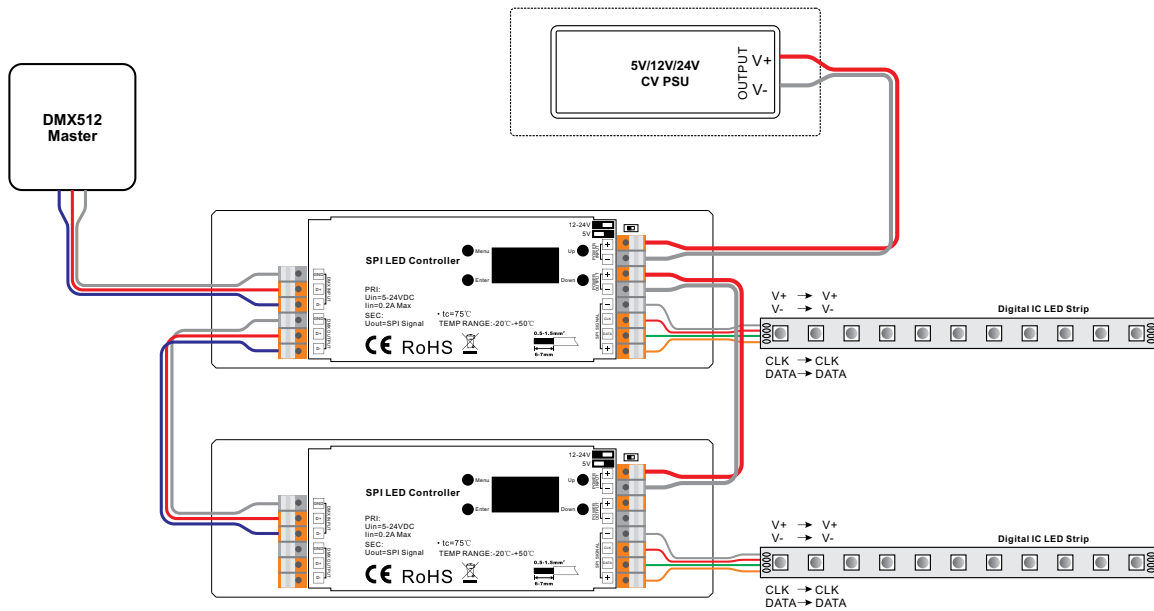

Power Input

5VDC/12-24VDC voltage can be set by DIP switch

End user must select the correct voltage appropriate to the type of LED pixel to be controlled before wiring.

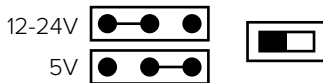

SPI signal output

+ is positive voltage output (voltage depends on input)

CLK is the Clock signal (only used with four wire pixels)

Data is the Data Signal (used on all pixels)

- is Negative voltage output (voltage depends on input)

Technical Information

DMX Mode

After choosing DMX mode and configuration of all settings, click "Menu" button to return to Menu select interface, click it again to show the detailed configuration information.

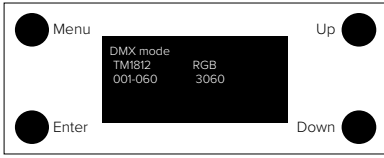

Under DMX mode, the controller is capable of addressing each pixel individually (3 DMX channels for each RGB pixel, 4 DMX channels for each RGBW pixel) or work with macro mode that allows you to address an entire string of RGB/RGBW pixels with just 3/4 channels.

DMX source device (DMX Console) and sequencing software (when not used in RF mode with built in sequences) are required for control under DMX mode.

Set DMX Address & Output Length

Each RGB pixel requires 3 DMX decoding channels, and each RGBW pixel requires 4. Please set the DMX address quantity as a multiple of 3 or 4.

For RGB pixels it's best to set the start address number as 001 or 001 plus a multiple of 3 (004, 007, 010...508) and set the end address as a multiple of 3 and greater than the start address (003, 006, 009...510)

For RGBW pixels it's best to set the start address number as 001 or 001 plus a multiple of 4 (005, 009, 013...509) and set the end address as a multiple of 4 and greater than the start address (004, 008, 012...512)

Each RGB pixel has 3 channels output, and each RGBW pixel has 4. Please set the output length (channels) as a multiple of the previously set DMX address quantity.

When addressing each pixel individually, the DMX channels for output channels of each pixel are as follows:

Addressing Up to 170 RGB Pixels individually

DMX Address	Pixel No.	Decoding Channel -> Output Channel
001-003	1st	1 -> R, 2 -> G, 3 -> B
004-006	2nd	4 -> R, 5 -> G, 6 -> B
007-009	3rd	7 -> R, 8 -> G, 9 -> B
010-012	4th	10 -> R, 11 -> G, 12 -> B
...
508-510	170th	508 -> R, 509 -> G, 510 -> B

Addressing Up to 128 RGBW Pixels individually

DMX Address	Pixel No.	Decoding Channel -> Output Channel
001-004	1st	1 -> R, 2 -> G, 3 -> B, 4 -> W
005-008	2nd	5 -> R, 6 -> G, 7 -> B, 8 -> W
009-012	3rd	9 -> R, 10 -> G, 11 -> B, 12 -> W
013-016	4th	13 -> R, 14 -> G, 15 -> B, 16 -> W
...
509-512	128th	509 -> R, 510 -> G, 511 -> B, 512 -> W